

HG50B



HG High-grade Sprocket with Hardened Teeth B-type

● Order No. Example

HG50B 42H

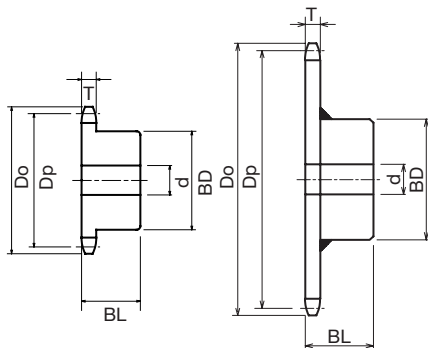
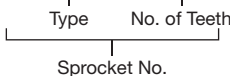

- ChainNo.50
- Chain Pitch(P)15.875mm
- Roller Link Inner Width(W) 9.53 mm
- Roller Outside Diameter(Dr)10.16 mm
- Tooth Width(T) 8.7 mm

m Carbon Structural Steel

h High-frequency Hardened Teeth

Type	No. of Teeth	Outer Diameter Do	Pitch Diameter Dp	Shaft Hole Diameter d			Boss Diameter BD	Boss Length BL	Shape	Weight kg	¥	Semi-F ¥
				Prepared Hole Product	Minimum	Maximum						
HG 50B	36H	191	182.14	19	20	55	83	35	Ground Specification	2.85		
	38H	201	192.24	19	20	55	83	35		3.05		
	39H	206	197.29	19	20	55	83	35		3.10		
	40H	211	202.33	19	20	55	83	35		3.25		
	42H	221	212.43	19	20	55	83	35		3.50		
	45H	237	227.58	19	20	55	83	35		3.85		
	48H	252	242.73	19	20	55	83	35	Welded Specification	4.20		
	50H	262	252.83	19	20	55	83	35		4.50		
	54H	282	273.02	19	20	55	83	35		5.05		
	60H	312	303.33	19	20	55	83	35		6.00		



Sprocket No. and Quantity



* Since we also manufacture sizes other than those in the catalog, and machine shaft holes/keys/taps, etc., depending on your request, please contact our company's sales office for details.



Same-day shipping

* Please refer to P24 to P33 for the Semi-F Series <Complete Product> order method.